

Directions for Assembling, Installing and Using Cover Basket Spa Cover Remover

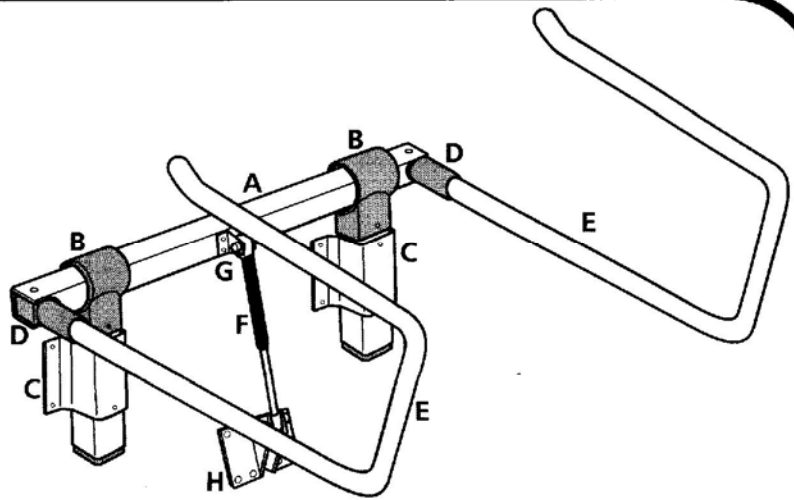

To assemble and install:

1. Keep Axle Bar **A** assembled as shipped.
2. Center Axle Bar **A** on the side of the spa that the cover is to be removed on.

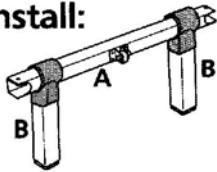

3. Position each Mounting Bracket **C** so that Bar **B** is 1-1/2" below the top of the spa lip.

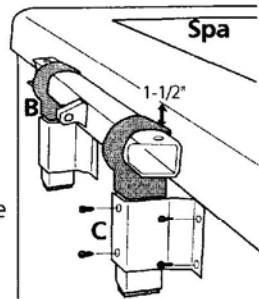

4. Position each Axle Adjustment Bar **B** 1/8" from the inside of the Elbow **D** insert hole at the end of Axle Bar **A**. Screw each Mounting Bracket **C** to the spa cabinet as close as possible to the bottom of the spa lip or top trim. Use the #10 x 1-1/4" screws provided. For spas with wide or irregular trim or 'picture frame' type cabinets, it may be necessary to insert a wood shim. When parts are in place and mounted to spa cabinet, lock **B** and **C** together by drilling the 1/2" self tapping screws into the holes provided on each bracket **C**.

5. Slide Catch Bar **E** into each Elbow **D**. Push the 1/4" x 1-3/4" bolts through the pre drilled holes, then install the flat washer and the nut. Install a 3/4" self-tapping screw into the side of Elbow **D** and Catch Bar **E**.

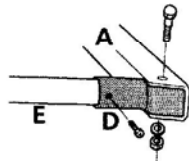

6. Screw the Gas Spring **F** into the Threaded Socket **G**, making sure both ends of the Gas Spring **F** are tightly screwed in Threaded Sockets **G** and **H**. The 1/4" bolts holding both Threaded Sockets **G** and **H** in their bracket should be loose enough to allow the Gas Spring **F** to move freely.

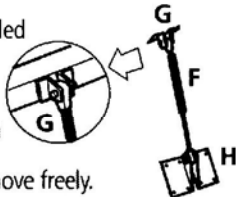

To assemble and install (continued):

7. To install the Gas Spring Bracket **H** to the spa cabinet, lift the Catch Bars **E** to the horizontal position, so the inside of the curve of the catch bar is level with the top of the spa lip, as shown. Insert the 1-1/4" screws into the pre-drilled holes in the Gas Spring Bracket **H**.

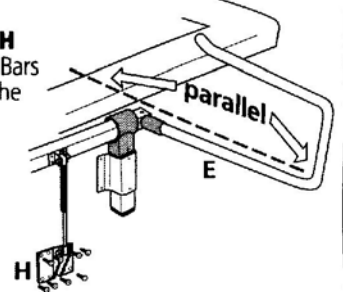

8. Affix each Black Plastic Bumper **I** to the spa cabinet by peeling off the adhesive strip and applying to the spa cabinet directly under the corner of the Catch Bar **E**, as shown. NOTE: The skirt must be clean and dry before applying the bumpers. (On oily surfaces, a screw or small nail may be required to hold the bumpers in place.)

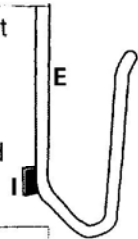

Please Note:

1. The **Cover Basket** is designed for the standard spa cabinet. Additional support may be required if the spa skirt was built with a lightweight material.
2. The **Cover Basket** is designed so the spa cover leans away from the spa. This is to prevent accidental damage to the cover remover.

To move the spa cover off:

1. FLIP COVER:
 2. SLIDE BACK:
 3. LOWER DOWN:
- THAT'S IT!**

NOTE: DO NOT SIT OR LEAN ON THE SPA COVER. DAMAGE MAY RESULT!